

N Series for Ethernet Isolated 32-bit Up/Down Counter Unit CNT-3204IN-ETH



* Specifications, color and design of the products are subject to change without notice.

Features

32-bit up-and-down counter

The 32 bit up-and-down counter could have four channels and up to 500kHz maximum speed pulse input. Moreover, it can count 2-phase signals and mono-phase signals such as a rotary encoder and a linear scale.

Bus isolation

The ethernet controller (PC) is isolated from I/O interface by an isolators, this product has excellent noise performance.

Control input/output signals and input signals for controlling sampling functions

One control input signal and one control output signal are provided for each channel.

This product can generate an interrupt, output an external signal, preset the counter, and clear it to zero when the count value matches the arbitrary value that is set. Moreover, this product has input signals (start/stop/clock) for controlling sampling functions.

Operable in a wide range of 12 - 24VDC power

The product can be operated in the various environments with a wide range power supply of 12 - 24VDC. In addition, the FG terminal is equipped in the power supply connector.

Compact design not restricting installation location (188.0(W) x 78.0(D) x 30.5(H))

Compact design of 188.0(W) x 78.0(D) x 30.5(H) does not require special installation location.

Usable as an Ethernet-based counter input

Monitoring up-and-down counter is easy as it can be controlled remotely through Ethernet.

Diverse installations such as screw fastening, magnet (optional purchase), DIN rail are possible

Installation on the floor / wall / ceiling is possible by screw fastening, with magnets (optional purchase), rubber feet, etc.

In addition, DIN rail mounting mechanism is equipped as standard with the product, making it easy to install the product within the panel or the device.

Easy-to-wire terminal connector adopted

Adoption of terminal connector (with screws) enables to achieve easy wiring.

Windows/Linux support device driver

Using the device driver API-TOOL makes it possible to create applications of Windows/Linux. In addition, a diagnostic program by which the operations of hardware can be checked is provided.

This product is an Ethernet-compliant counter unit, which adds the function of counting pulse signals input from external devices through a LAN port to a PC.

It has four channels of 32-bit up/down counters, allowing external devices such as a rotary encoder and a linear scale to be connected. The pulse signal inputting interface is optocoupler isolated.

Compact design, (188.0(W)×78.0(D)×30.5(H)mm), features flexibility in installation. The product can be set on the floor, wall, and inside the console or equipment with the DIN rail.

Windows/Linux device driver is supported with this product.

- * The contents in this document are subject to change without notice.
- * Visit the CONTEC website to check the latest details in the document.
- * The information in the data sheets is as of February, 2024.

Included Items

- | | |
|-------------------------------|-------------------------------|
| Product ...1 | Power supply connector...1 |
| Interface connector(8pin)...4 | Rubber feet...4 |
| Interface connector(4pin)...1 | Please read the following...1 |

Support Software

Name	Contents	How to get
Windows Version Counter Input Driver software API-CNT(WDM)	The Windows device driver is provided as a form of Windows API functions. Various sample programs such as C# and Visual Basic .NET, Visual C++, Python etc. and diagnostic program useful for checking operation is provided.	Download from the CONTEC website *1
Linux Version Counter Input Driver software API-CNT(LNX)	The Linux device driver is provided as a shared library. The software includes various sample programs such as gcc (C, C++) and Python programs, as well as a configuration tool to configure the device settings.	Download from the CONTEC website *1
Software Development Tool Kits (SDK) and Support Software	In addition to the device drivers, we offer many software programs for using CONTEC devices in an easier manner.	Download from the CONTEC website *1

*1 Download the files from the following URL
<https://www.contec.com/download/>

*2 For supported software, search the CONTEC website for this product and view the product page.
<https://www.contec.com/>

Optional Products

Product Name	Model type	Note
AC-DC Power Adaptor (12VDC, 1A)	POA201-10-2	*1
CONPROSYS Series Magnet (Four Piece Set)	CPS-MAG01-4	
CONPROSYS Series 12VDC AC-DC Converter	CPS-PWD-15AW12-01	*2
CONPROSYS Series 12VDC AC-DC Converter	CPS-PWD-30AW24-01	*2
CONPROSYS Series 12VDC AC-DC Converter	CPS-PWD-90AW24-01	*2

*1 The operating ambient temperature is 0 to 40 °C. It is the same adaptor included in this package.

*2 The operating ambient temperature is -20 to 70 °C.

Specifications

Function specification

Item	Specification
Input *1	
Counter	
Channel count	4 channels
Count system	Up/down counting (2-phase/Single-phase/Single-phase Input with Gate Control Attached)
Max. count	FFFFFFFFh (binary data, 32Bit)
Input type	Optocoupler isolated input
Input signal	Phase-A/UP 1 x 4 channels, Phase-B/DOWN 1 x 4 channels Phase-Z/CLR 1 x 4 channels
Input resistance	220 Ω (5V external power supply), 690 Ω (12V external power supply)
Response frequency	500kHz 50% duty
External Power	5VDC±10% or 12VDC±10%
Digital filter	0.1μsec - 1.6384msec or not used (can be independently set for each channel)
Counter start trigger	Software/External start input/Sampling start trigger
Counter stop trigger	Software/External stop input/Sampling stop trigger
Sampling	
Sampling start trigger	Software/External start input/Count match
Sampling stop trigger	Software/External stop input/Specification number/ Data transfer error/Count match
Sampling clock	Sampling timer/External dock input
Sampling timer	2μsec - 107sec 25nsec unit (can not be independently set for each channel)
External sampling start signal	Isolated TTL level input (Select Rise or Fall)
External sampling stop signal	Isolated TTL level input (Select Rise or Fall)
External sampling clock signal	Isolated TTL level input (Fall)
Response frequency	500kHz 50% duty
Control	
Control input signal type	Optocoupler isolated input
Control input channel	1 x 4 channels
Control input signal	- Preset (Select Rise or Fall) - Zero-clear (Select Rise or Fall) - Counter start/stop (Select Rise or Fall) - General-purpose input (positive logic) Software-selected from among the above four options
Response time	100μsec (Max)
Interrupt event	Count match (8 points), Counter error (2 points), Sampling factor (6 points), Carry/Borrow (1 points)
Output *1	
Control	
Control output signal type	Optocoupler isolated open collector output
Control output channel	1 x 4 channels
Control output signal	- Count match 0 output(one-shot pulse output) - Count match 1 output(one-shot pulse output) - Digital filter error output(one-shot pulse output) - Abnormal input error output(one-shot pulse output) - General-purpose output(Level output) Software-selected from among the above five options (Positive/negative logic is selected with the software.)
One shot output signal amplitude	Selected between 10μsec, 100μsec, 1msec, 10msec and 100 msec (Can be set for each channel within precision + 1μsec)
Response time	5μsec (Max)
Output rating	35VDC, 50mA(Max)
External Power	5V - 12VDC±10%
LAN section *2	
Transmission standard	10BASE-T/100BASE-TX
Connector	RJ-45 connector
LED	Speed(Orange), Link / Act(Green)
Power supply	
Input voltage range	12 - 24VDC±10%
Current consumption	12VDC 160mA(Max), 24VDC 80mA(Max)
Power supply connector	European type terminal 3.5mm pitch 3-pin jack connector
Common section	
Interface connector	Counter and Control : European type terminal 3.5mm pitch 8-pin jack connector x4 Sampling : European type terminal 3.5mm pitch

Item	Specification
	4-pin jack connector x1
Dielectric strength	1000VAC
Physical dimensions (mm)	188.0(W)×78.0(D)×30.5(H) (No protrusions)
Weight	250g

*1 Use the shielded cable for this product to meet "CE EMC Directive".

*2 Use an STP cable.

Installation Environment Requirements

Item	Specifications	
Operating ambient temperature *1	-20 - +60°C *2	
Operating ambient humidity	10 - 90%RH (No condensation)	
Floating dust particles	Not to be excessive	
Corrosive gases	None	
Line-noise resistance *3	Line noise	AC Line/±2kV, Signal Line/±1kV (IEC61000-4-4 Level 3, EN61000-4-4 Level 3)
	Static electricity resistance	Contact discharge /±4kV (IEC61000-4-2 Level 2, EN61000-4-2 Level 2) Air discharge /±8kV (IEC61000-4-2 Level 3, EN61000-4-2 Level 3)
Vibration resistance	Sweep resistance	10 - 57Hz /semi-amplitude vibration 0.15mm, 57 - 150Hz/2G 40minutes each in X, Y, and Z directions (JIS C60068-2-6-compliant, IEC60068-2-6-compliant)
	Shock resistance	147m/s ² (15G)/11ms/half-sine shock (JIS C 60068-2-27-compliant, IEC 60068-2-27-compliant)
Standard	VCCI Class A, FCC Class A, CE Marking (EMC Directive Class A, Low Voltage Directive, RoHS Directive), UKCA	

*1 To suppress the heating, ensure that there are spaces for ventilation (about 5cm) around this product.

*2 When using the supplied AC adaptor POA 201-10-2, it is 0 - 40°C.

*3 When using the supplied AC adaptor POA 201-10-2.

Physical Dimensions

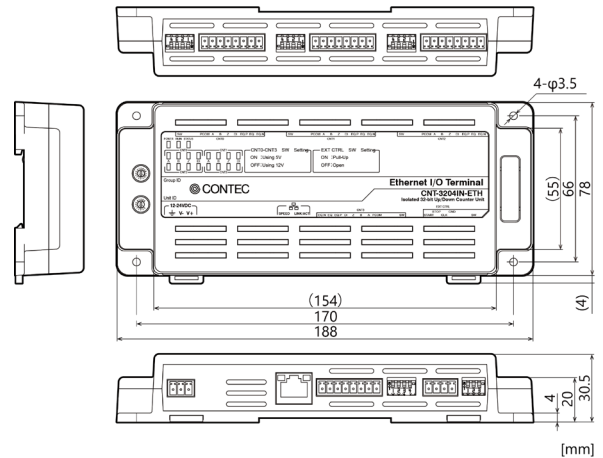

Component Name

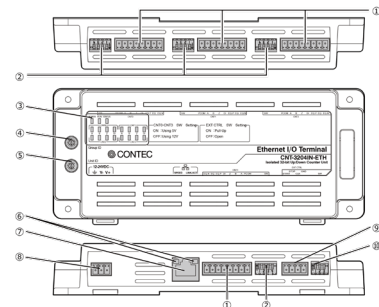

No.	Name	No.	Name
1	Interface Connector (8-pin)	6	LAN LED
2	Input resistance setting switch	7	Ethernet Connector
3	LED Indicator	8	Power Supply Connector (Attached connector)
4	Setting Switch: Group ID	9	Interface connector (4-pin)
5	Setting Switch: Unit ID	10	Pull-up setting switch

Signal Layout on the Interface Connector

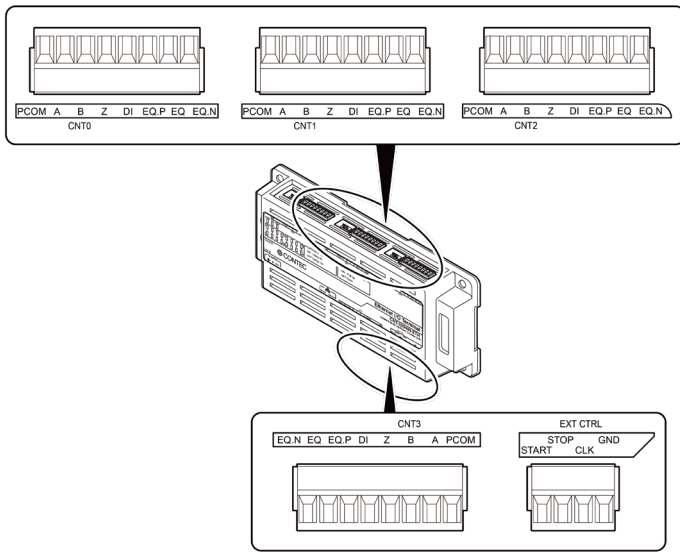

CNT0 ~ CNT3	Signal name	Function
	PCOM	Plus common of input signal. Connect the positive side of external power supply.
	A	Phase-A input
	B	Phase-B input
	Z	Phase-Z input
	DI	Control input (this can be used as a general-purpose input/hardware event)
	EQ.P	Plus common of equal output. Connect the positive side of external power supply.
	EQ	Count equal output/General-purpose output.
	EQ.N	Negative common of equal output. Connect the negative side of external power supply.

Support cable:

AWG28-16(Cable length should satisfy the power specification including the cable voltage drop)

EXT CTRL	Signal name	Function
	GND	Ground of external sampling start/stop/clock signal.
	CLK	External sampling clock signal.
	STOP	External sampling stop signal.
	START	External sampling start signal.

Support cable:

AWG28-16(Cable length should satisfy the power specification including the cable voltage drop)

Counter Input Circuit and Control Input Circuit

The figure below shows the equivalent circuit of counter input section and control input section of this product.

The signal input section consists of an opto-coupler isolated input (compatible with current sink output). Set an external power voltage and input resistance value according to the output specification of the external device to be connected.

As for the counter input section, connect both phase A and phase B for a two-phase input.

Connect either phase A or phase B for a single-phase input. If not using the Z phase, this does not need to be connected.

In addition, the control input section can also be used as the input section for the start / stop signal of general-purpose input and count operation, preset signal of count value.

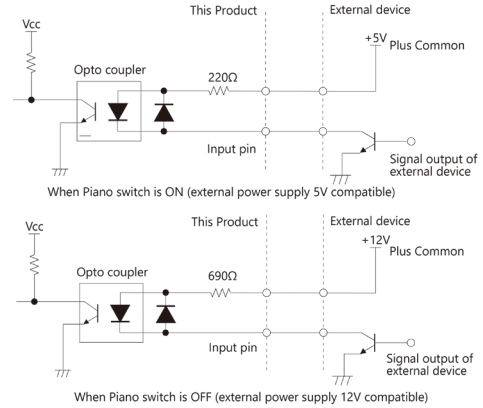

CAUTION

To use external power (other than 5V or 12V); insert a current limiting resistor at the R position.

The following expression is used to calculate current limiting resistance R with the external power supply as PV:

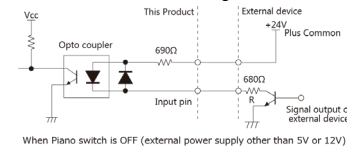

The expression is as follows;

$$\frac{PV-12}{20} < Rk\Omega < \frac{PV-12}{15}$$

If PV=24V, use a 600Ω < R < 800Ω resistor.

Control Output Circuit

The figure below shows the output circuit of control output section of this product.

The signal output section consists of an opto-coupler isolated open collector output (current sink type). An external power supply is therefore required to drive the output section of this product.

The maximum output current rating per channel is 50 mA for the product.

Zener diodes are connected to the output transistor to protect against surge voltages.

As for the control output section, it is also possible to output a one-shot pulse signal at the time of hardware event occurs, such as a general-purpose output and count match.

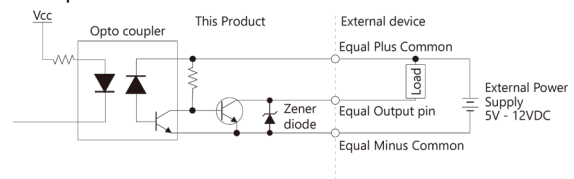

CAUTION

- Negative logic is set as default. (Negative logic is also set when setting is empty)
- When the power is turned on, all output will be OFF.

Surge voltage countermeasure

When connecting a load that generates surge voltages and inrush currents, such as an induction load (relay coil) or an incandescent light bulb, to the control output signal, appropriate protection must be provided in order to prevent damage to the output stage or a malfunction due to noise. The rapid shutoff of a coil, such as a relay, generates a sudden high-voltage pulse. If this voltage exceeds the voltage tolerance level of the output transistor, it can cause the transistor to gradually deteriorate, or even completely damage the transistor. Therefore, when driving an induction load, such as a relay coil, you should always connect a surge-absorbing device. The following illustrates a surge voltage countermeasure that can be employed:

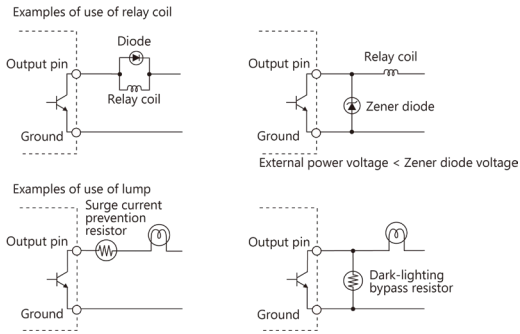

CAUTION

The protection circuit will not be effective unless it is installed less than 50cm from the load and contact.

Sampling Control Input Circuit

The figure below shows the circuit of signal input for sampling control section of this product.

These inputs are used for the start signal, the stop signal and the clock signal of sampling operation.

The signal input section consists of a digital isolated and TTL input. This section can set the pull-ups, so that the device that outputs a TTL level signal and also the device that outputs an open-collector can be connected. The pull-up voltage is 5V. If it is necessary to pull-up with different voltage such as 3.3V, turn off the pull-up setting and pull-up at the external device side.

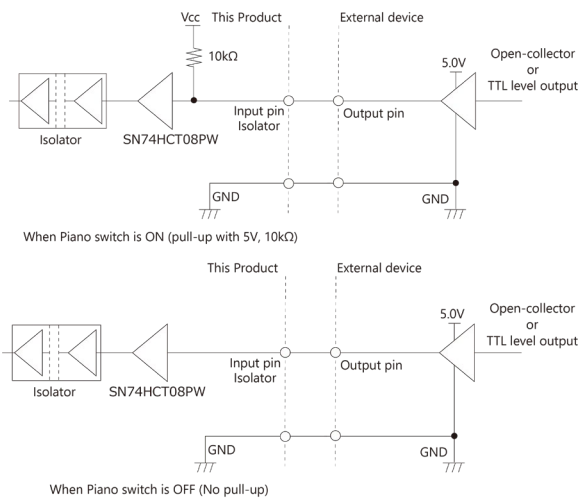

CAUTION

Turn on the pull-up setting when sampling control input is not used. It may affect the unconnected control input terminal when pull-up voltage is not connected.

Power Supply Connector

Connect this product to the external power supply with the supplied power input connector.

When using a commercially available DC output power supply, follow the same procedure described here.

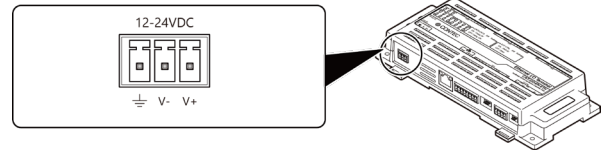

Mark	Signal Name
⊕	Frame ground (FG)
V-	Power supply (GND)
V+	Power supply (12 - 24VDC)

Connecting to an External Power Supply for Driving the Product

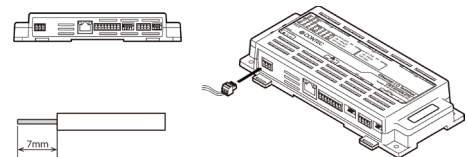

When supplying power using the supplied power supply connector or the supplied connector plug, strip off approximately 7mm (±0.5mm) of the covered part of the cable and insert it into the connector plug and securely screw it in place.

When connecting the FG pin of the product to ground (earth), follow the same procedure.

Use the power cable described below.

Cable	Twisted pair cable (when using a single wire, twist V+ wire and V- wire)
Cable Diameter	AWG24 - 16(0.2mm ² - 1.25mm ²)
Cable Length	Within 3 meters

Use the FG cable described below.

Cable Diameter	AWG18 - 16(0.75mm ² - 1.25mm ²)
----------------	--

About a power rise

When using a commercially available DC output power supply, use a power supply with an input voltage that rises to above 11.4VDC and below 12 to 24VDC (+10%) within 10ms. A power supply that does not rise to this level may not operate the product properly or may cause a product failure or accident.

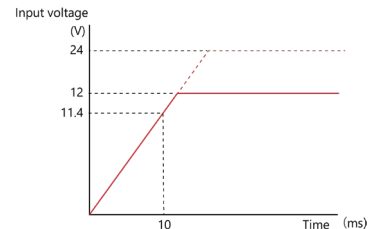

Connecting an external power supply

Use an external power supply as necessary for the environment and application.

When using the separately sold AC adapter POA201-10-2 or DIN rail fitting power supply, connect the connector included with that product to the power supply connector, and do not use the supplied power supply connector. Use an external power supply as necessary for the environment and application.

Connecting the AC Adapter POA201-10-2 (Option)

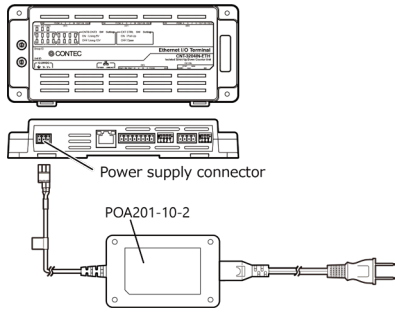

Connecting DIN rail fitting power supply (Option)

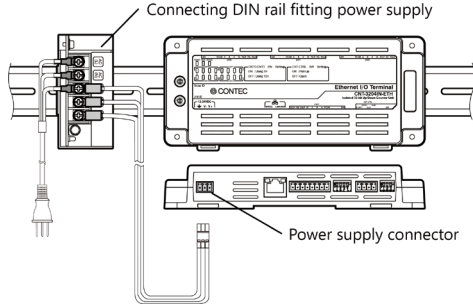

CAUTION

- Refer to the specifications in "Function Specifications" for the required input power specifications per unit of this product.
- The tightening torque for the supplied power supply connector is 0.25N·m.
- If the maximum output current of the external power supply does not include a sufficient margin compared with the maximum current consumption of the product, abnormal operation may occur due to the inrush current at startup or load fluctuations, or a start failure may occur due to degradation of the power supply over time.
- When the product is not used, leave the 12 - 24VDC power supply (such as the separately sold AC adapter) unplugged.
- Connect the 12-24VDC power supply (such as the separately sold AC adapter) to the power supply connector of the product first. When unplugging, unplug it from the power outlet side of the AC adapter first.
- Grasping the cable to remove the power supply connector of the 12-24VDC can break the wire. Always grasp the connector to remove it.
- When the 12-24VDC power supply is supplied, do not disconnect the 12-24VDC power supply from the power supply connector.
- If you use this product in a noisy environment, connect the FG pin of the product to the ground (earth) to stabilize the operation.
- Using the separately sold AC adapter in a heated state continuously affects its life.
- Use the separately sold AC adapter not in a closed place but in a well-ventilated place to prevent the product from being overheated.
- Do not remove the power supply connector [MC1.5/3-ST-3.5] that is attached to the separately sold AC adapter.

Circuit Block Diagram

