

CONPROSYS Series
5 port 10/100M Unmanaged
Industrial Switching HUB
CPS-HBL-8005F



* Specifications, color and design of the products are subject to change without notice.

Features

With its compact size, it corresponds to 100BASE-TX in five all ports.
 This product contains five ports for IEEE802.3u (100BASE-TX)/ IEEE802.3 (10BASE-T) in the compact size (25.2(W) x 94.7(D) x 124.8(H) mm).

2-way power connector and reverse wiring protection within
 The product supports 2-way power supply. Even when one of the power systems fails during the operation, the product continues functioning. Our safety design supports the product to function even when wires are connected in reverse.

Adaptable to a wide range of temperature between -20 and +60°C
 The product is capable of operating in the temperature between -20 and + 60°C. It can be installed in the various environments.

For Auto MDI/MDI-X feature, auto-negotiation feature
 The Auto MDI/MDI-X feature automatically determines straight or cross cable, avoiding wiring trouble due to wiring mistake. Moreover, auto-recognition function of communication rates (10/100Mbps) and communication methods (half/full duplex) by the auto-negotiation feature.

Installation on DIN rail is possible.
 As the product is mounted on the 35mm DIN rail, removing and replacing are easy as well.

Compatible with 12 - 24VDC wide range power
 It is compatible with 12 - 24VDC wide range power and can be used in various power environment. In addition, An FG terminal is equipped in the power connector.

Packing List

- Unit...1
- Please read the following...1
- Power Supply Connector...2 (attached to the product)

*The manual of this product can be downloaded from CONTEC website free of charge (<http://www.contec.com/>).

Optional product

- POA201-10-2: AC adaptor (Input: 90 - 264VAC, Output: 12VDC 1.0A)

* Information about the option products, see the Contec's website.

This product is a compact-sized industrial switching HUB [25.2(W) x 94.7(D) x 124.8(H) mm] with 5 ports for IEEE802.3u(100BASE-TX) / IEEE802.3(10BASE-T) compliant.

In addition, the Auto MDI/MDI-X features automatic negotiation. An ideal product for the place where quietness is required as it contains no fan. Moreover, the product can operate in the temperature between -20 and + 60°C. There are two supplies of power, and function that prevents power from connecting in reverse.

- * The contents in this document are subject to change without notice.
- * Visit the CONTEC website to check the latest details.
- * The information in the data sheets is as of May, 2023

Specifications

Item	Specifications
Ethernet standards	IEEE802.3/IEEE802.3u --compliant
Data transfer rate	10Mbps/100Mbps (auto-negotiation)
Access method	CSMA/CD
Communications method	All ports: Full/Half duplex (auto-negotiation)
Topology	Star topology
Flow control	Full Duplex : IEEE802.3x compliant flow control Half Duplex : Back pressure
Number of effective ports	5
Switching method	Store and forward
Filtering speed	8,130pps(at 10Mbps)/ 148,800pps(at 100Mbps)
Forwarding speed	8,130pps(at 10Mbps)/ 148,800pps(at 100Mbps)
Address table	1,024 entries
Buffer capacity	448Kbits
Aging time	300sec (Max)
LED indicator	POWER(Green), LINK/ACT (Green), SPEED 10/100M(Yellow-green)
Power supply voltage	8V - 35VDC±5%
Hybrid supply system *1	Enable
Reverse polarity protection	Enable
FG pin	Power supply connector equipped with FG pin
Power consumption (Max)	When inputting 8V : 0.14A, When inputting 35V : 0.04A
Physical dimensions (mm)	25.2(W)×94.7(D)×124.8(H) (exclusive of protrusions)
Material of the case	Plastic shell
Weight	170g
Module installation method	Quick mounting onto 35mm DIN rail.

*1 The product can function by one of the power connectors. Even when one power turns off during the operation, the product continues functioning.

Installation Environment Requirements

Item	Specifications	
Operating temperature *2	-20 - +60°C	
Storage temperature	-20 - +60°C	
Humidity	10 - 90%RH (No condensation)	
Floating dust particles	Not to be excessive	
Corrosive gases	None	
Line-Noise resistance	Line-noise	AC line/2kV, Signal line/1kV (JIS C61000-4-4Level 3, EN61000-4-4Level 3)
	Static electricity	Contact discharge/4kV (JIS C61000-4-2Level 2, EN61000-4-2Level 2)
	resistance	Atmospheric discharge/8kV (JIS C61000-4-2Level 3, EN61000-4-2Level 3)
Vibration resistance	Sweep resistance	10 - 57Hz/semi-amplitude 0.15mm, 57 - 150Hz/2.0G 40minutes each in X, Y, and Z directions (JIS C60068-2-6-compliant, IEC60068-2-6-compliant)
	Impact resistance	15G, half-sine shock for 11ms in X, Y, and Z directions (JIS C60068-2-27-compliant, IEC60068-2-27-compliant)
Protection	IP20	
Grounding	Class D grounding (previous class 3 grounding)	
Standard	VCCI Class A, FCC Class A, CE Marking (EMC Directive Class A, RoHS Directive), UL, UKCA	

*2 POA201-10-2 of the optional products is capable of operating in the temperature between 0 and +40°C.

External Dimensions

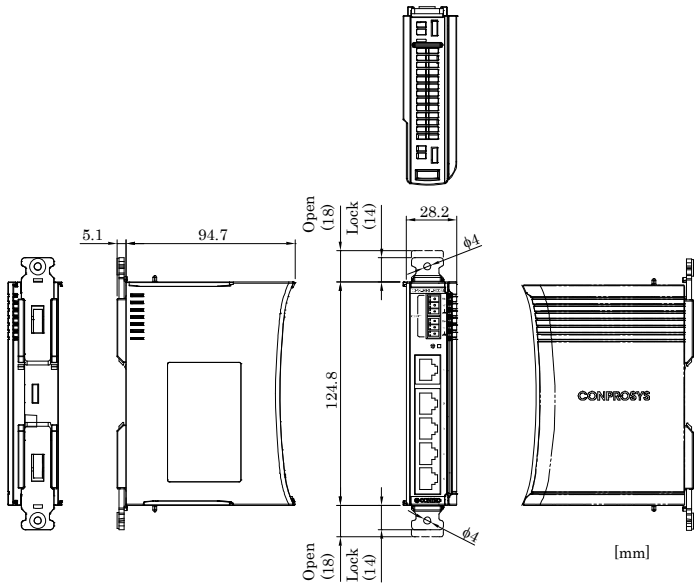

Component Name

Names of Components and Functions

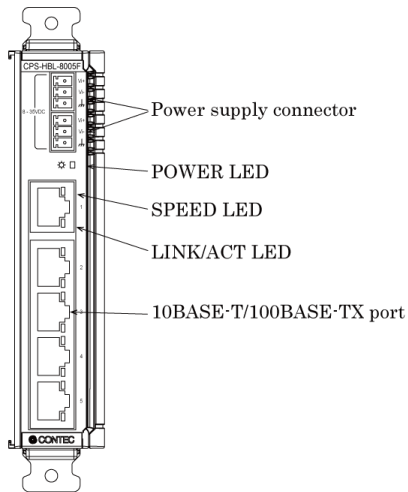

LED Indicators

Name	Color	Content of Display
POWER LED	Green	ON : Power on OFF : Power off
SPEED LED	Yellow - green	ON : Indicates linking by 100Mbps OFF : Indicates linking by 10Mbps or not linked.
LINK/ACT LED	Green	ON : Linking Flashing : indicates data sending/ receiving with connected external devises OFF : No Linking