

Digital Input Board with Opto-Isolation for PCI Express  
**DI-64L-PE**

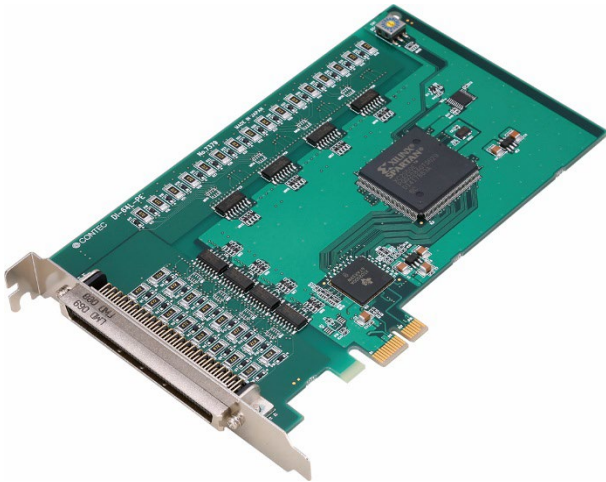

\* Specifications, color and design of the products are subject to change without notice.

**Features**

**Opto-coupler isolated input (supporting current sink output)**

DI-64L-PE has the 64ch of opto-coupler isolated input (supporting current sink output) whose response time is 200μsec. Common terminal provided per 16channels, capable of supporting a different external power supply. Supporting driver voltages of 12 - 24 VDC for I/O.

**Opto-coupler bus isolation**

As the PCI Express bus (PC) is isolated from the input interfaces by opto-couplers, this product has excellent noise performance.

**32 input signals can be used as interrupt request signals**

You can use 32 input signals as interrupt request signals and also disable or enable the interrupt in bit units and select the edge of the input signals, at which to generate an interrupt.

**Windows/Linux support device driver**

Using the device driver API-TOOL makes it possible to create applications of Windows/Linux. In addition, a diagnostic program by which the operations of hardware can be checked is provided.

**Equipped with digital filter to prevent wrong recognition of input signals from carrying noise or a chattering**

This product has a digital filter to prevent wrong recognition of input signals from carrying noise or a chattering. All input terminals can be added a digital filter, and the setting can be performed by software.

**Functions and connectors are compatible with PCI compatible board PIO-32/32L(PCI)H series.**

DI-64L-PE: The functions same with PCI compatible board PI-64L(PCI)H are provided. In addition, as there is compatibility in terms of connector shape and pin assignments, it is easy to migrate from the existing system.

This product is a PCI Express bus-compliant interface board for input of digital signals. This product can input digital signals at 12 - 24VDC.

DI-64L-PE features 64 opto-coupler isolated inputs (supporting current sink output). You can use 32 input signals as interrupt inputs. In addition, the digital filter function to prevent wrong recognition of input signals is provided.

Windows/Linux device driver is supported with this product.

\*The contents in this document are subject to change without notice.

\*Visit the CONTEC website to check the latest details in the document.

\*The information in the data sheets is as of February 2024.

**Specification**

Item		Specifications
Input	Type	Opto-Isolated Input (for current sinking output) (Negative logic *1)
	Number of Channels	64ch (32 channels available for interrupts) (One common power supply per 16 channels)
	Input resistance	4.7kΩ
	Current required to turn ON	2.0mA or more
	Current required to turn OFF	0.16mA or less
	Interrupts	Combine 32 interrupt signals to one interrupt request signal as the INTA. Either rising edge or falling edge of input signal can generate interrupt.
	Response time	200μsec within
Common	Connecting distance	50m (Typ.)(depending on wiring environment)
	I/O address	Any 32-byte boundary
	Interruption level	1 level use
	Boards in one system	Maximum of 16 boards can be install in a same system.
	Isolated voltage	500Vrms
	External circuit power supply	12 - 24VDC (±10%)
	Power consumption	3.3VDC 350mA (Max)
	Bus specification	PCI Express Base Specification Rev. 1.0a x1
	Dimension (mm)	169.33(L) x 110.18(H)
Weight	215g	

\*1 Data "0" and "1" correspond to the High and Low levels, respectively.

**Installation Environment Requirements**

Item	Specifications
Operating ambient temperature	0 - +50°C
Operating ambient humidity	10 - 90%RH (No condensation)
Floating dust particles	Not to be excessive
Corrosive gases	None
Standard	VCCI Class A, CE Marking (EMC Directive Class A, RoHS Directive), UKCA

**Physical Dimensions**



The standard outside dimension (L) is the distance from the end of the card to the outer surface of the slot cover.

## Support Software

Name	Contents	How to get
Windows Version Digital I/O Driver software API-DIO(WDM)	The Windows device driver is provided as a form of Windows API functions. Various sample programs such as C# and Visual Basic, .NET, Visual C++, Python etc. and diagnostic program useful for checking operation is provided.	Download from the CONTEC website *1
Linux Version Digital I/O Driver software API-DIO(LNX)	The Linux device driver is provided as a shared library. The software includes various sample programs such as gcc (C, C++) and Python programs, as well as a configuration tool to configure the device settings.	Download from the CONTEC website *1
Software Development Tool Kits (SDK) and Support Software	In addition to the device drivers, we offer many software programs for using CONTEC devices in an easier manner.	Download from the CONTEC website *2

\*1 Download the files from the following URL

<https://www.contec.com/download/>

\*2 For supported software, search the CONTEC website for this product and view the product page.

<https://www.contec.com/>

## Optional Products

Product Name	Model type	Description
Shielded Cable with Two 96-Pin Half-Pitch Connectors	PCB96PS-0.5P	0.5m
	PCB96PS-1.5P	1.5m
	PCB96PS-3P	3m
	PCB96PS-5P	5m
	PCB96PS-10P	10m
Flat Cable with 96-pin Half-Pitch Connectors at Both Ends	PCB96P-1.5	1.5m
	PCB96P-3	3m
Shielded Cable with One 96-pin Half-Pitch Connector	PCA96PS-0.5P	0.5m
	PCA96PS-1.5P	1.5m
	PCA96PS-3P	3m
	PCA96PS-5P	5m
Flat Cable with One 96-pin Half-Pitch Connector	PCA96P-1.5	1.5m
	PCA96P-3	3m
Connection Conversion Shield Cable (96P→37P x 2)	PCB96WS-1.5P	1.5m
	PCB96WS-3P	3m
	PCB96WS-5P	5m
Screw Terminal (M3 * 96)	EPD-96A	*1 *2
Terminal Unit for Relay Terminal Banks	EPD-96	*2
Screw Terminal (M3 * 37P)	EPD-37A	*1 *3
Screw Terminal (M3.5 * 37)	EPD-37	*3
Screw Terminal	DTP-64A	*2
General Purpose Terminal	DTP-3C	*3
Screw Terminal	DTP-4C	*3
Signal monitor Accessory for Digital I/O (64bits)	CM-64L	*2
Signal monitor Accessory for Digital I/O (32bits)	CM-32L	*3
Connector Conversion Board (96pin→37pinx2)	CCB-96	*4

\*1 "Spring-up" type terminal is used to prevent terminal screws from falling off.

\*2 PCB96P or PCB96PS optional cable is required separately.

\*3 PCB96WS optional cable is required separately.

\*4 Option cable PCB96P or PCB96PS, and the cable for 37-pin D-SUB are required separately.

## Packing List

Product ...1

Please read the following ... 1

## Connecting an Interface Connector

To connect an external device to this product, plug the cable from the device into the interface connector (CN1) shown below.

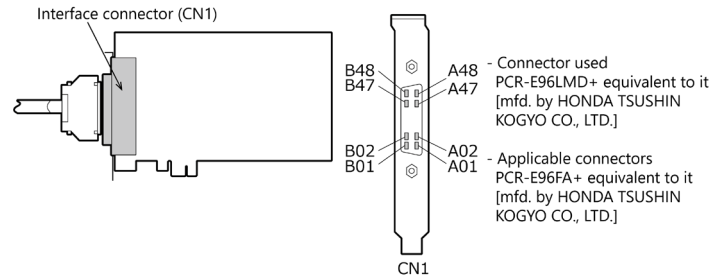

### Layout on the Interface Connector(CN1)

Common plus pin for +6/+7 input ports	IP-6/7	B48	A48	IP-2/3	Common plus pin for +2/+3 input ports		
+7 port (Input)	IP-6/7	B47	A47	IP-2/3	+3 port (Input)		
	I-77	B46	A46	I-37			
	I-76	B45	A45	I-36			
	I-75	B44	A44	I-35			
	I-74	B43	A43	I-34			
	I-73	B42	A42	I-33			
	I-72	B41	A41	I-32			
	I-71	B40	A40	I-31			
	I-70	B39	A39	I-30			
	+6 port (Input)	I-67	B38	A38		I-27	+2 port (Input)
I-66		B37	A37	I-26			
I-65		B36	A36	I-25			
I-64		B35	A35	I-24			
I-63		B34	A34	I-23			
I-62		B33	A33	I-22			
I-61		B32	A32	I-21			
I-60		B31	A31	I-20			
N.C.		N.C.	B30	A30	N.C.	N.C.	
		N.C.	B29	A29	N.C.		
	N.C.	B28	A28	N.C.			
	N.C.	B27	A27	N.C.			
	N.C.	B26	A26	N.C.			
	N.C.	B25	A25	N.C.			
	N.C.	B24	A24	N.C.			
	N.C.	B23	A23	N.C.			
	N.C.	B22	A22	N.C.			
	N.C.	B21	A21	N.C.			
Common plus pin for +4/+5 input ports	IP-4/5	B20	A20	IP-0/1	Common plus pin for +0/+1 input ports		
	IP-4/5	B19	A19	IP-0/1			
+5 port (Input)	I-57	B18	A18	I-17	+1 port (Input)		
	I-56	B17	A17	I-16			
	I-55	B16	A16	I-15			
	I-54	B15	A15	I-14			
	I-53	B14	A14	I-13			
	I-52	B13	A13	I-12			
	I-51	B12	A12	I-11			
	I-50	B11	A11	I-10			
	+4 port (Input)	I-47	B10	A10		I-07	+0 port (Input)
		I-46	B09	A09		I-06	
I-45		B08	A08	I-05			
I-44		B07	A07	I-04			
I-43		B06	A06	I-03			
I-42		B05	A05	I-02			
I-41		B04	A04	I-01			
N.C.	N.C.	B02	A02	N.C.	N.C.		
	N.C.	B01	A01	N.C.			

\* I-00 - I-37 can be used as interrupt signal.

The numbers in square brackets [ ] are pin numbers designated by HONDA TSUSHIN KOGYO CO., LTD.

Signal name	Description
I-00 - I-77	64 input signal pins. Connect output signals from the external device to these pins.
IP-0/1	Connect the positive side of the external power supply. These pins are common to 16 input signal pins.
IP-2/3	Connect the positive side of the external power supply. These pins are common to 16 input signal pins.
IP-4/5	Connect the positive side of the external power supply. These pins are common to 16 input signal pins.
IP-6/7	Connect the positive side of the external power supply. These pins are common to 16 input signal pins.
N.C.	This pin is left unconnected.

**CAUTION**

To perform input using this product with the CONTEC device driver, specify logical ports and logical bits when calling each function. For details, refer to the "Relationships between API-TOOL Logical Ports/Bits and Connector Signal Pins" of Reference Manual.

**Pin Assignments of Optional Connector PCB96WS**

- Option cable PCB96WS-\*\*

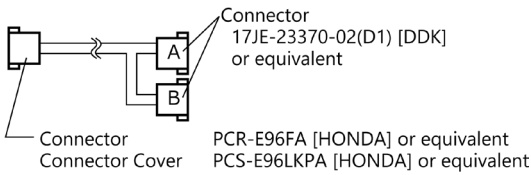

CNA				CNB			
	N.C.	20	1	N.C.	20	1	N.C.
+2 port (Input)	I-20	21	2	I-00	21	2	I-40
	I-21	22	3	I-01	22	3	I-41
	I-22	23	4	I-02	23	4	I-42
	I-23	24	5	I-03	24	5	I-43
	I-24	25	6	I-04	25	6	I-44
	I-25	26	7	I-05	26	7	I-45
	I-26	27	8	I-06	27	8	I-46
+3 port (Input)	I-27	28	9	I-07	28	9	I-47
	I-30	29	10	I-10	29	10	I-50
	I-31	30	11	I-11	30	11	I-51
	I-32	31	12	I-12	31	12	I-52
	I-33	32	13	I-13	32	13	I-53
	I-34	33	14	I-14	33	14	I-54
	I-35	34	15	I-15	34	15	I-55
Common plus pin for +2/+3 input ports	I-36	35	16	I-16	35	16	I-56
	I-37	36	17	I-17	36	17	I-57
	IP-2/3	37	18	IP-0/1	37	18	IP-6/7
	N.C.	19		N.C.	19		N.C.

**Pin Assignments of Optional Connector CCB-96**

- "Optional cable PCB96PS" + "Connector conversion board CCB-96"

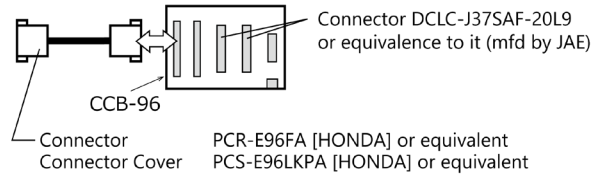

CN3(CNA)			
	N.C.	1	20
+0 port (Input)	I-00	2	21
	I-01	3	22
	I-02	4	23
	I-03	5	24
	I-04	6	25
	I-05	7	26
	I-06	8	27
+1 port (Input)	I-07	9	28
	I-10	10	29
	I-11	11	30
	I-12	12	31
	I-13	13	32
	I-14	14	33
	I-15	15	34
Common plus pin for +0/+1 input ports	I-16	16	35
	I-17	17	36
	IP-0/1	18	37
	N.C.	19	

CN4(CNB)			
	N.C.	1	20
+4 port (Input)	I-40	2	21
	I-41	3	22
	I-42	4	23
	I-43	5	24
	I-44	6	25
	I-45	7	26
	I-46	8	27
+5 port (Input)	I-47	9	28
	I-50	10	29
	I-51	11	30
	I-52	12	31
	I-53	13	32
	I-54	14	33
	I-55	15	34
Common plus pin for +4/+5 input ports	I-56	16	35
	I-57	17	36
	IP-4/5	18	37
	N.C.	19	

**Connecting Input Signals**

**Input Circuit**

Connect the input signals to a device which can be current-driven, such as a switch or transistor output device.

The connection requires an external power supply to feed currents. The product inputs the ON/OFF state of the current-driven device as a digital value.

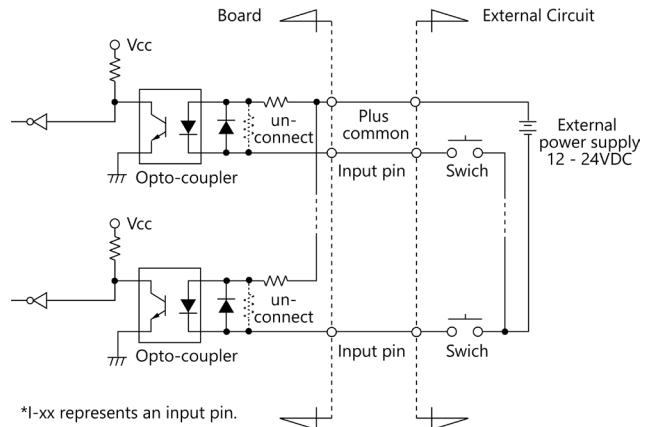

The signal inputs are isolated by opto-couplers (ready to accept current sinking output signals). The product therefore requires an external power supply to drive the inputs. The power requirement for each input pin is about 5.1 mA at 24 VDC (about 2.6 mA at 12 VDC).

**Connecting a Switch (An Example to use Input I00)**

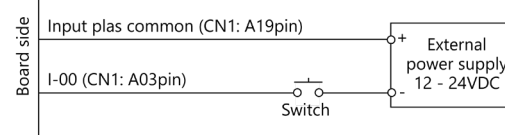

When the switch is ON, the corresponding bit contains 1. When the switch is OFF, by contrast, the bit contains 0.

### Connecting the Sink Type Output and Sink Output Support Input

The following example shows a connection between a sink type output (output board) and a sink output support input (input board). Refer to this connection example when you connect such boards to each other.

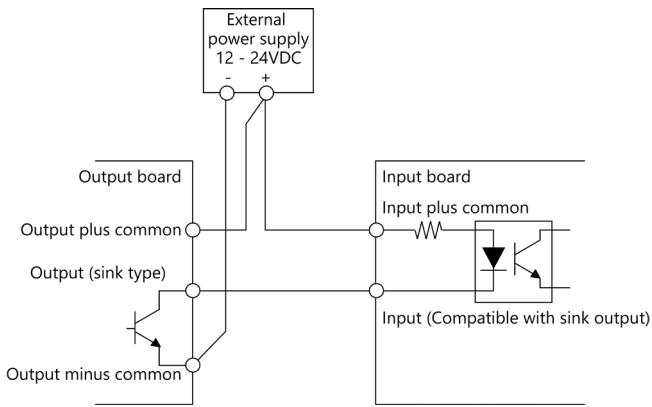

### Block Diagram

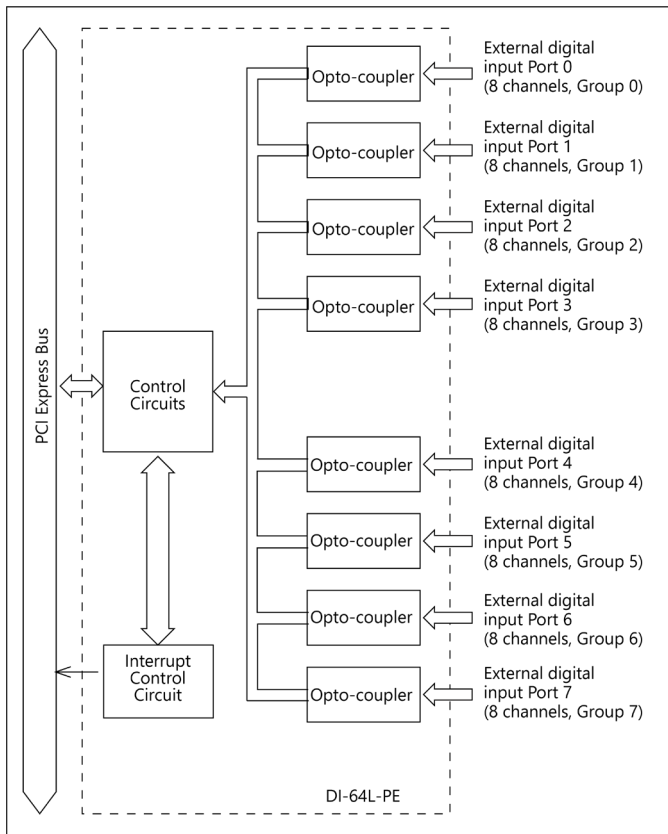

### Nomenclature of Product Components

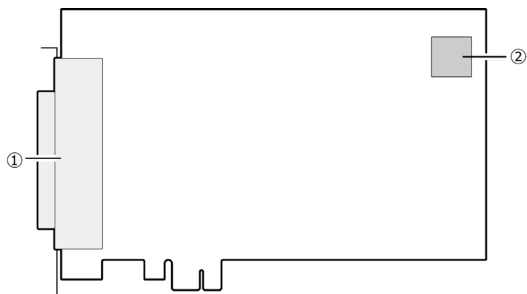

No.	Name
1	Interface Connector
2	Board ID Setting Switch